

This Space For Architect/Engineer Approval

Job Name \_\_\_\_\_ Date \_\_\_\_\_

Model Specified \_\_\_\_\_ Quantity \_\_\_\_\_

Customer/Wholesaler \_\_\_\_\_

Contractor \_\_\_\_\_

Architect/Engineer \_\_\_\_\_

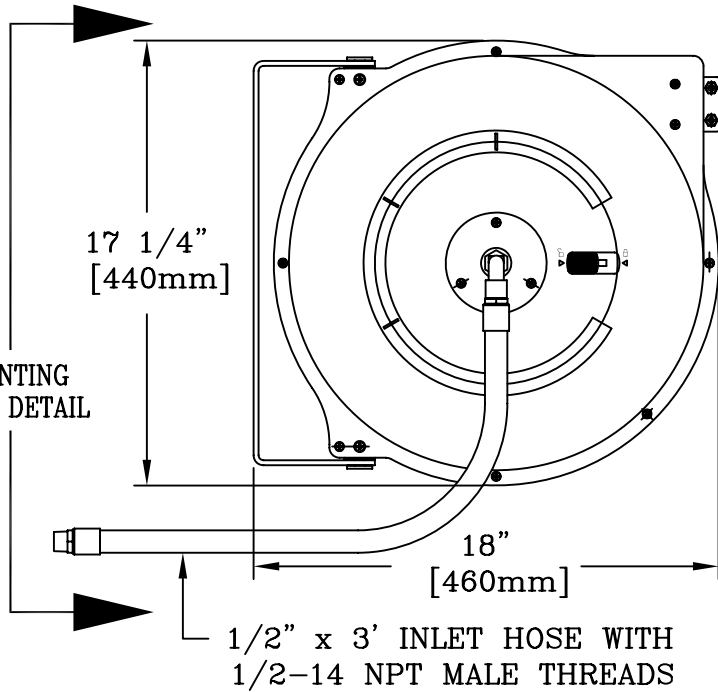

5WG-1001-01 WATER GUN  
w/ 1/2" NPT FEMALE x  
GARDEN HOSE MALE  
ADAPTER

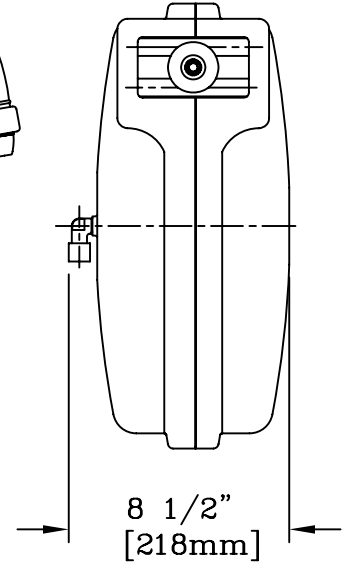

SEE MOUNTING  
BRACKET DETAIL

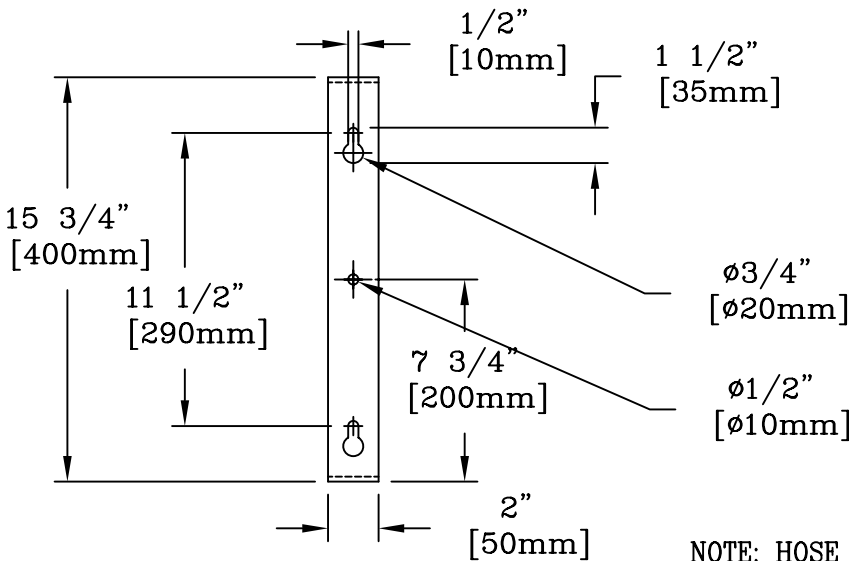

MOUNTING BRACKET DETAIL  
BRACKET DISASSEMBLED FROM REEL

FURNISHED WITH 360°  
SWIVEL CONNECTOR: 1/2" NPT  
FEMALE x GARDEN HOSE  
FEMALE

FURNISHED w/  
FEMALE GARDEN  
HOSE  
QUICK-DISCONENCT.  
INCLUDES 3/8" NPT  
FEMALE & 1/2" NPSM  
FEMALE ADAPTERS

NOTE: HOSE RATINGS ARE AS FOLLOWS:  
PRESSURE: 300 PSI MAX.  
TEMPERATURE: 0°-158°F

MODEL NUMBER 5HR-343-09

DATE 3/21/06

SCALE 1:8

DRAWN DHL

CHECKED WJS

APPROVED JHB



DESCRIPTION

ENCLOSED HOSE REEL, PLASTIC, w/50' OF 1/2" DIA. HOSE AND 5WG-1000-01 WATER GUN

equip Foodservice Accessories  
P.O. BOX 1088, 2 SADDLEBACK COVE  
TRAVELERS REST, SOUTH CAROLINA 29690  
PHONE: 800.891.4808 FAX: 800.868.0084