



T&S BRASS AND BRONZE WORKS, INC.

2 SADDLEBACK COVE / P.O. BOX 1088 / TRAVELERS REST, SC 29690

PHONE 800-476-4103

FAX 864-834-3518



REG.#A2601  
ISO #9002

Model No.

B-2350

Item No.:

Job Name:

Architect/Engineer Approval:

Notes:



ADA COMPLIANT

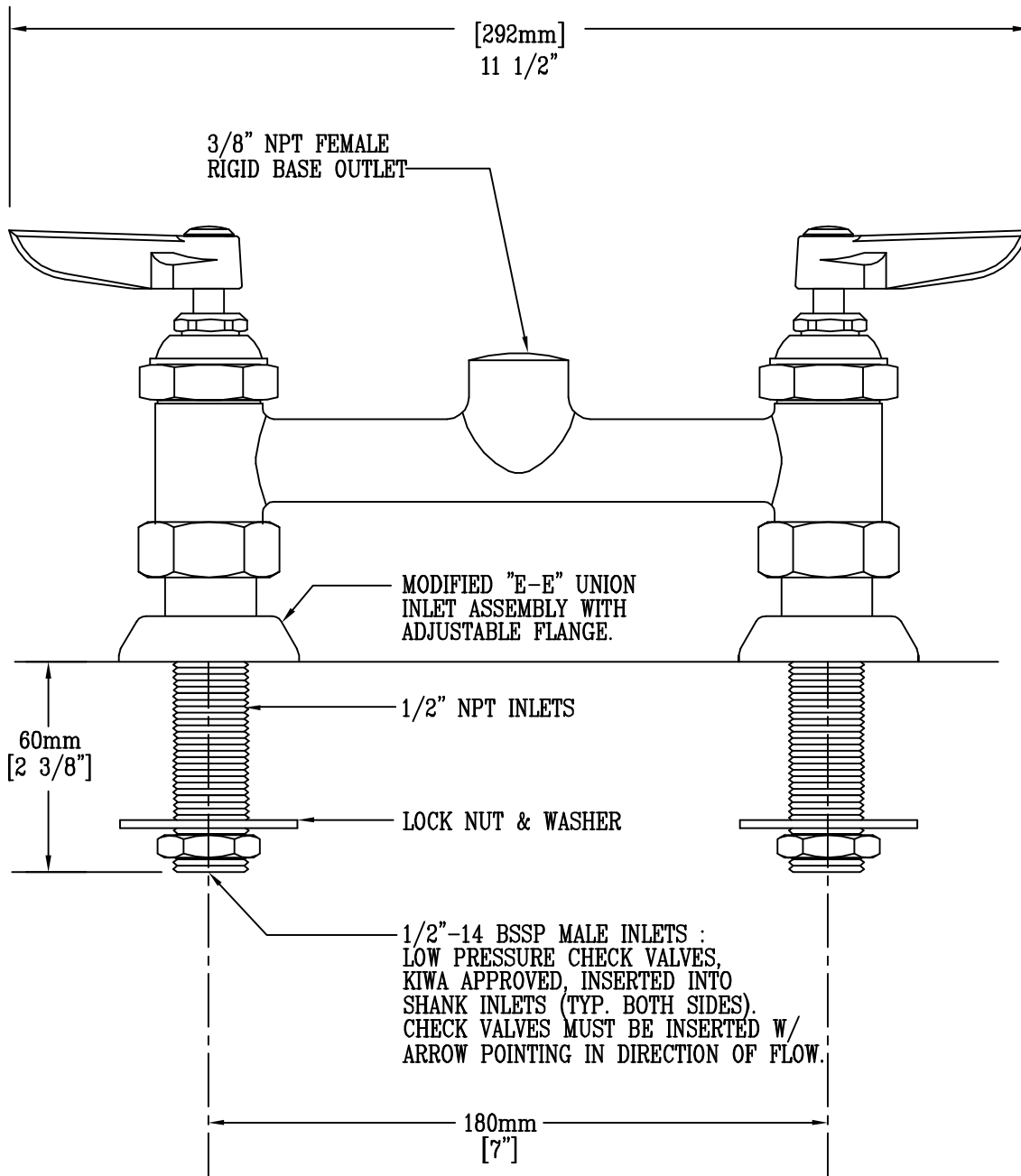

Product Description:

180mm RIGID BASE FAUCET WITH  
MODIFIED "E-E" INLETS, SHANK CHECK VALVES,  
& 1/2" BSSP MALE INLET SHANKS

Drawn:

WJS

Checked

ARD

Scale:

6"=1'

Approved

CA

Date:

3/14/96